



GREENWAY FUNDAMENTALS PRESENTATION

GREENWAYS FOR PITTSBURGH | PRESENTATION DATE | LOCATION

A GREENWAY IS...

A Greenway is defined as a permanently conserved, primarily passive open space that is stewarded primarily by the community and serves to benefit adjacent neighborhoods and the general public.

- Greenways for Pittsburgh 2.0 Definition (January 2017)



Greenways benefit adjacent neighborhoods and the general public by achieving specific goals:

A Greenway is defined as a permanently conserved, primarily passive open space that is stewarded primarily by the community and serves to benefit adjacent neighborhoods and the general public.

- Greenways for Pittsburgh 2.0 Definition (January 2017)



Greenways benefit adjacent neighborhoods and the general public by achieving specific goals:

Equity
Ecology
Economy
Placemaking
Connectivity

EQUITY

Improve access to green space
Improve access to passive recreation
Help communities build capacity

ECOLOGY

Preserve and restore native species and ecological restoration
Manage stormwater and improve air quality
Protect wildlife habitats and reduce the heat island effect

ECONOMY

Raise investment in communities through capacity building
Provide opportunities for workforce development
Reduce the impacts of illegal dumping and blighted parcels

PLACEMAKING

Protect aesthetic character of Pittsburgh's hillsides
Provide quality green space in and between communities
Preserve cultural and historic assets

CONNECTIVITY

Improve connectivity for pedestrians and cyclists
Improve mobility and ecological connectivity between greenspaces



GREENWAY TYPOLOGIES



GREENWAY TYPOLOGIES

Conservation Greenway

All Pittsburgh greenways promote conservation, but some serve only that purpose.

Conservation greenways contain ecologically sensitive lands such as:

- Steep slopes
- Landslide prone slopes
- Undermined hilltops
- Stormwater and floodways

Conservation greenways allow for:

- Ecological preservation
- Stormwater management



GREENWAY TYPOLOGIES

Passive Greenway

Most Pittsburgh greenways allow for passive uses.

Passive greenways contain:

- Trails
- Overlooks and scenic views
- Natural or cultural heritage assets

Passive greenways also allow uses that do not require permanent infrastructure, special equipment, or maintenance such as:

- Hiking
- Biking

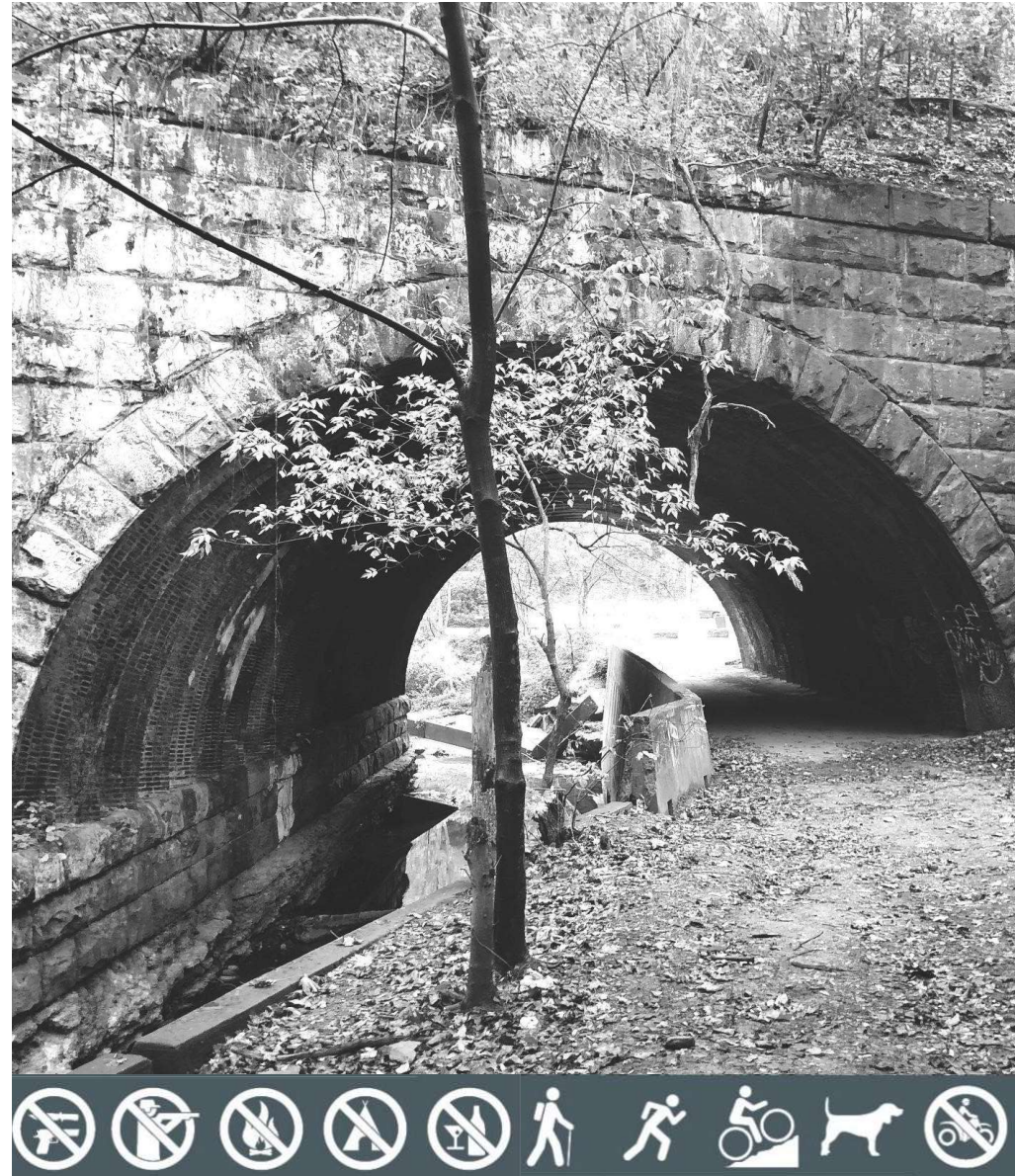

GREENWAY TYPOLOGIES

Active Sites

Some greenways include Active Sites with higher levels of recreational activity.

Any activities which require permanent infrastructure, special equipment, or specialized maintenance are limited to designated active sites. Some activities at these sites would either be individually permitted by the City or administered by a vendor with a lease from the City.



Other elements may exist within any of the greenway typologies where appropriate:



MOBILITY CORRIDOR

Mobility corridors are easements through greenways maintained by the City. Mobility corridors provide improved connectivity to pedestrians and cyclists throughout the City. They include City Steps or rights-of-way.



UTILITY EASEMENT

Utility easements are locations where existing utility infrastructure passes through a greenway. These easements fall under the operator's responsibility for routine maintenance.



TEMPORARY GREENWAY

Temporary greenway parcels are parcels adjacent to designated greenway parcels that are not officially part of the greenway but may function as a greenway. These parcels may be sold in the future. Permanent improvements should not be made to Temporary Greenway parcels.



GREENWAY TYPOLOGIES

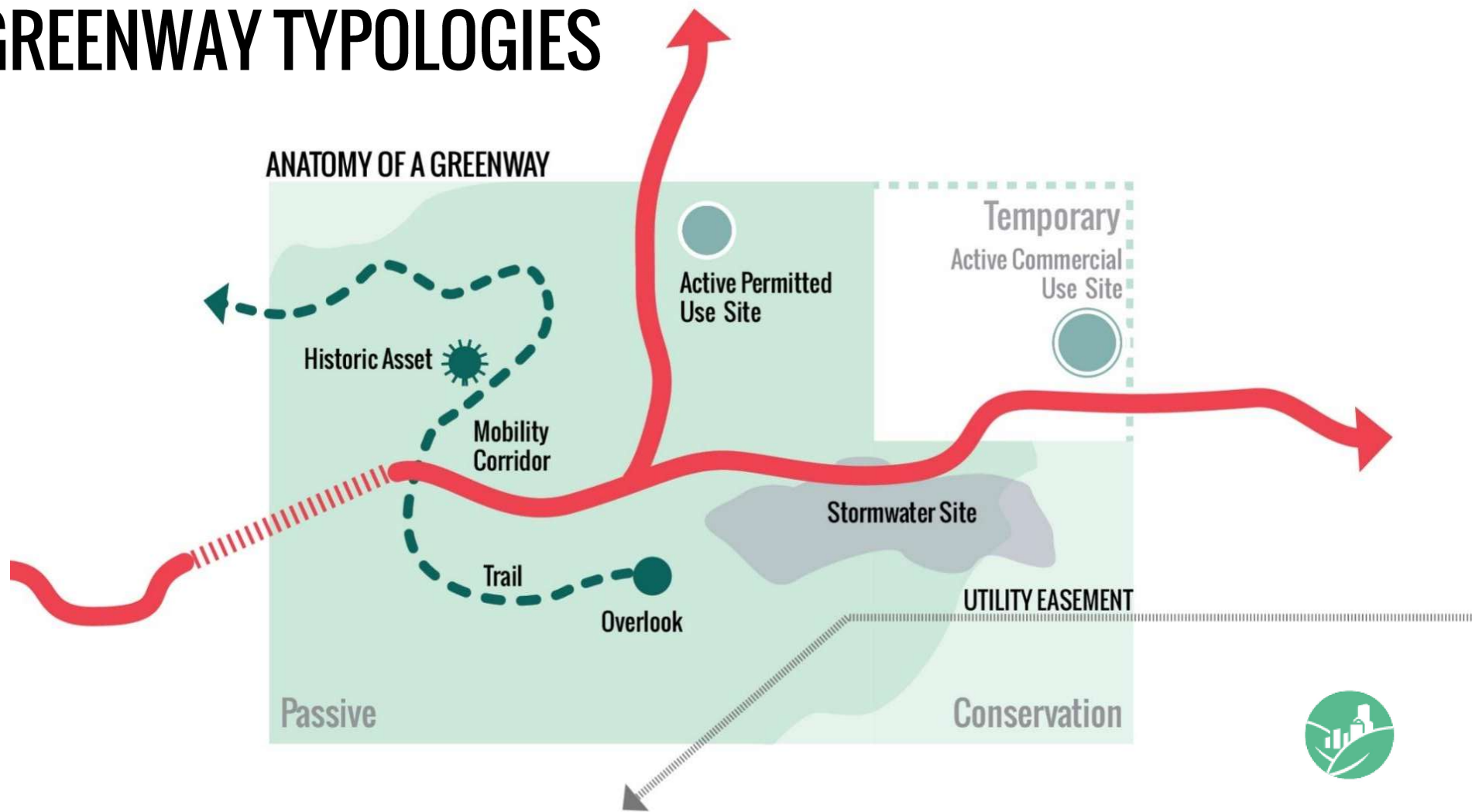

GREENWAYS FOR PITTSBURGH v1 (1980)

The Greenways for Pittsburgh program was established in 1980 to designate steeply sloped, unbuildable land for the purpose of protecting hillsides and preserving passive open space.

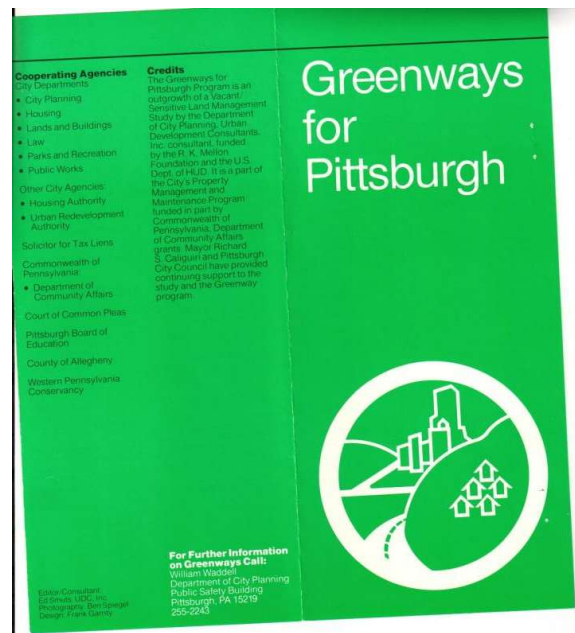
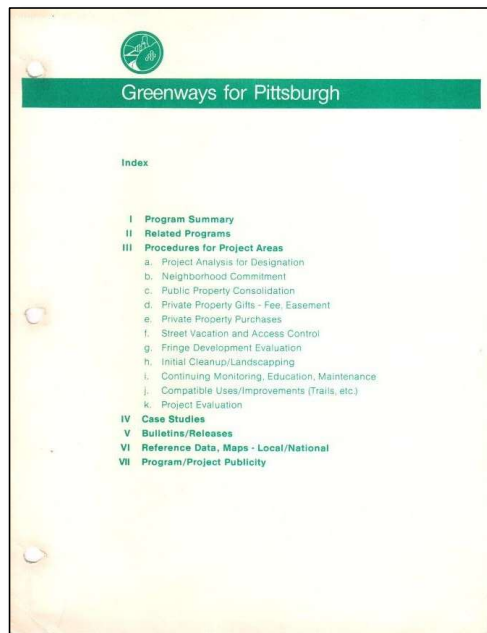

Today, the City has twelve designated Greenways totaling 605 acres, and greenways contribute to 14% of Pittsburgh's public open space.

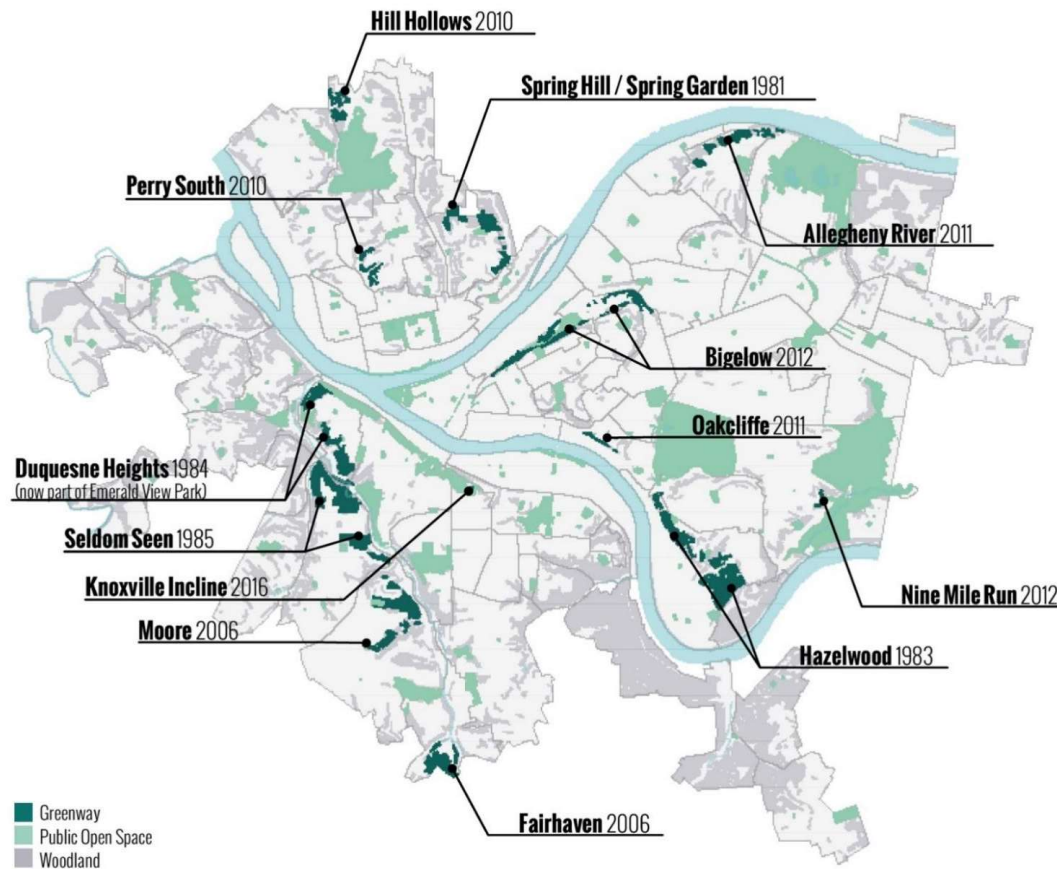



HAZELWOOD GREENWAY



HAZELWOOD GREENWAY



HAZELWOOD GREENWAY



DUQUESNE HEIGHTS (now part of Riverview Park)



DUQUESNE HEIGHTS (now part of Riverview Park)



SELDOM SEEN GREENWAY



SELDOM SEEN



KNOXVILLE INCLINE

Knoxville Incline Greenway

Greenway hours are Sunrise to Sunset

The following is prohibited:
 Littering or dumping debris
 Using illegal drugs or alcohol
 Panhandling or solicitation
 Rumormongering through trash bins

Permits are required for:
 Amusement rides
 Commercial activity or concessions
 Consuming alcohol
 Performing or playing

Welcome to your Greenway.
 This greenway is a shared public space, open space provided for your enjoyment. Have a fun and safe time. Be courteous and respectful to others, and please keep the greenway clean.



Stewards:
 South Side Stages
 Neighborhood Association
 Altoness Community Development Corporation

For more information about the Incline, call the 24/7 Incline Office at 615.253.4444 or visit knoxville.gov/incline



KNOXVILLE INCLINE

GREENWAYS FOR PITTSBURGH 2.0 (2017)

During the creation of Pittsburgh’s Open Space Plan (2013), public input from across the city indicated that communities wanted more greenways to improve access to trails and natural areas, and to connect parks and other open spaces into a network of open spaces.

The Greenways 2.0 program is a “refresh” of the program and describes the processes, policies, and stewardship guidelines for greenways. The new program encourages stewardship, improves the quality, connectivity, and accessibility of greenways, and helps the city reach its ambitious sustainability goals with regards to conservation and green infrastructure.



GREENWAYS FOR PITTSBURGH 2.0 (2017)



POLICY GUIDE
for the City



RESOURCE GUIDE
for stewards



COMMUNITY ENGAGEMENT TOOLKIT
for stewards

EXISTING GREENWAYS

The City strongly recommends that existing Greenways complete some of the requirements outlined in the five phase designation process as a way to find answers for these and other questions.

Do you want to improve your greenway but don't know how?

Are you lacking capacity to maintain and operate your greenway?

WE TAKE CARE OF AN EXISTING GREENWAY!

Do you steward an existing greenway?



NEW GREENWAYS

New greenways are required to go through the entirety of the greenway process. Visit the Greenways website and read the Resource Guide for more information.

Is there a large area of hillside woodlands in your neighborhood?

WE WANT TO START A GREENWAY!

Are you excited about the idea of having an officially designated Greenway in your community?

Do you love the idea of preserving green space and creating trails?



WHO IS INVOLVED?

Greenways Advisory Panel (GAP)

Individuals from the City who advise the Greenway Program Manager on efforts related to individual greenways.

Greenways Program Manager (GPM)

The GPM is the single point of contact for the Greenways Program. They provide oversight of the program and are available to answer questions and guide you through the process.

Greenway Stewardship Group (GSG)

Every greenway has a community-based and community-lead GSG. The GSG is responsible for maintaining and operating the greenway, conducting community outreach, and implementing ongoing projects.

Greenway Partner (GP)

These groups have demonstrated experience working in greenways and are often the first choice to work with GSGs.

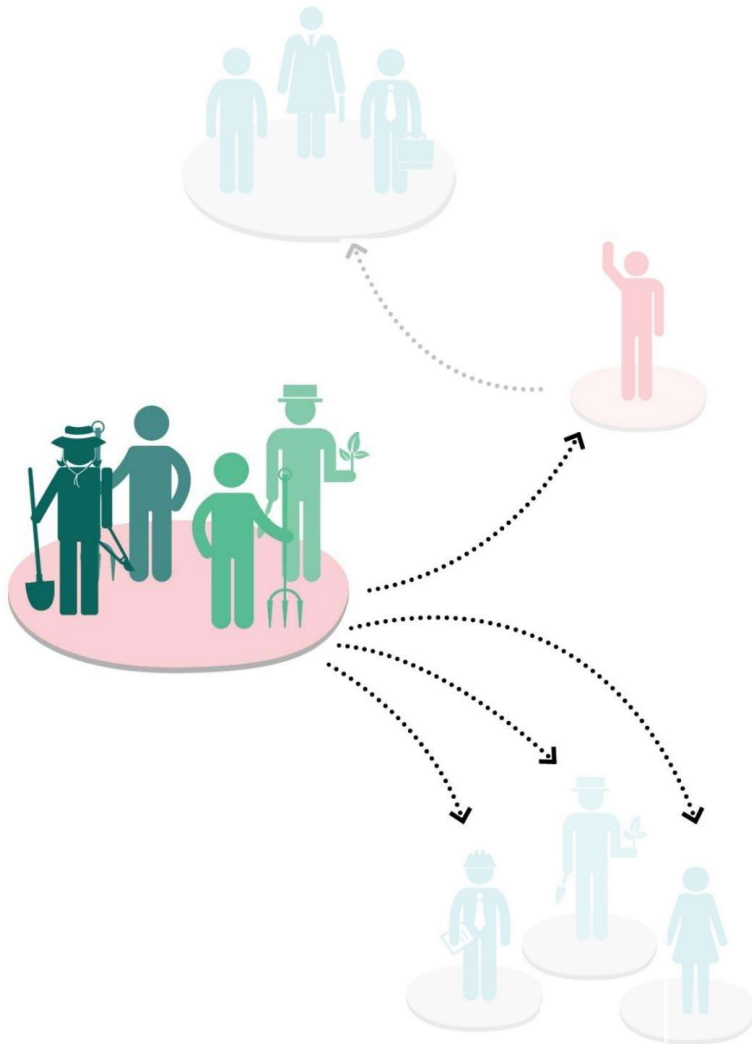

GREENWAY PROCESS

PHASES NEW GREENWAYS		EXISTING GREENWAYS
1	<p>INITIATION</p> <p>This phase contains the preliminary work completed by a community or the City to test if a group of parcels would be viable as a greenway.</p> <p>OUTCOME: PRELIMINARY DESIGNATION PLAN ENDORSED</p>	Complete an abbreviated version.
2	<p>DESIGNATION</p> <p>This phase contains the preliminary work completed by a community or the City to test if a group of parcels would be viable as a greenway.</p> <p>OUTCOME: GREENWAY OFFICIALLY DESIGNATED</p>	Complete an abbreviated version.
3	<p>IMPLEMENTATION PLAN</p> <p>This phase focuses on creating a master implementation plan for the greenway.</p> <p>OUTCOME: IMPLEMENTATION PLAN ENDORSED</p>	Complete phase in full.
4	<p>PROJECTS</p> <p>This phase contains the preliminary work completed by a community or the City to test if a group of parcels would be viable as a greenway.</p> <p>OUTCOME: GREENWAY LAUNCHES</p>	Continue to perform under new requirements.
5	<p>STEWARDSHIP</p> <p>This phase focuses on operating and maintaining the greenway, completing new projects, and annual reporting.</p> <p>OUTCOME: CONTINUED OPERATIONS AND MAINTENANCE</p>	Continue to perform under new requirements.

ELEMENTS

What makes a great greenway?

Greenways are often inspired by someone imagining a trail, overlook, or other amenity in the wooded area in their neighborhood. However, greenways are more than just a collection of inspired projects. Greenways artfully organize different elements to make enjoyable spaces that are available to all. To make a truly fantastic greenway, consider the following principles when developing your implementation plan:

Connect to other green spaces and surrounding neighborhoods

CONNECTIONS

Integrate community ideas, needs, priorities, participation, and actions

COMMUNITY

Use clear signage and information to encourage visitors and raise awareness

VISIBILITY

Choose appropriate plants and materials to increase lifespan and reduce maintenance

RESILIENCE

Protect from illegal activities such as dumping, motorized vehicles, hunting, and encroachment

PROTECTION

Create enjoyable projects to keep the community active and engaged.

I WANT OUR GREENWAY TO BE AWESOME!



How to Make Planning Decisions

There are many options to consider when developing an implementation plan for your greenway, and it can sometimes be difficult to cooperate when establishing priorities. Consider the following when making decisions regarding your greenway's implementation plan priorities:

What did the community members say?

Use voting or other techniques to quantify community wishes for the greenway.

Does this support our vision and goals?

If suggested projects are not in support of the greenway vision and goals, they should not be a first priority.

How much funding do we have available?

Choosing low or no cost projects first can help build momentum with a small budget.

Can we use workforce development or another benefit?

Choosing projects that create jobs or training opportunities for community members provides the greenway with a dual benefit.

Can everyone use it?

Who can utilize the project once it is complete should be considered when making decisions (can only able bodied individuals use it?).



Greenway Elements

The following greenway elements can be built and/or acquired for a greenway, depending on whether it is a passive or conservation greenway.

	<p>ENTRY SIGNAGE</p> <p>Greenway signage is standardized and should follow the City's Open Space Signage Standard. Signs should be located at every major entry and can either be freestanding or attached to access control fencing.</p> <p>The signs should:</p> <ul style="list-style-type: none"> • Identify the greenway (name) • Provide regulatory information • Provide directional information (maps) <p>Who is responsible for this? DCP is responsible for designing the signs. Stewards are responsible for purchasing, mounting, and installing the signs.</p>
	<p>TRAIL AND MILE MARKERS</p> <p>Greenway trail markers are standardized and should follow the City's Open Space Signage Standard. At the least, trail markers should be located at every trail intersection. Trail markers are only required for trails that exceed 2 miles in length. Trail blazing and/or adding attachments to trees is prohibited.</p> <p>The markers should:</p> <ul style="list-style-type: none"> • Identify the trail name and difficulty • Identify the mileage • Provide directions <p>Who is responsible for this? DCP is responsible for designing the trail markers. Stewards are responsible for purchasing, mounting, and installing the signs.</p>
	<p>BENCHES</p> <p>Benches provide a nice resting place for visitors. They should be placed along trails, near to entry points, and at points of interest (such as overlooks). Benches should be set back from a trail by more than 3 feet but less than 10 feet to ensure that the bench does not encroach within the trail or encroach within the naturalized greenway interior. Along a trail, distance between benches should be at least 200 feet.</p> <p>Who is responsible for this? Stewards are responsible for purchasing, building, and installing benches. All benches must follow DCP standards.</p>

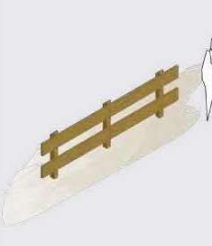
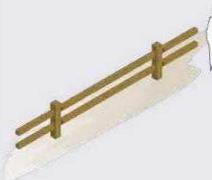
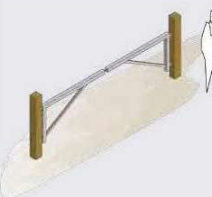
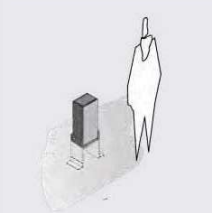
	<p>ACCESS CONTROL FENCE</p> <p>Access control fences are taller than other greenway fences to make it more challenging for individuals to access the greenway. This type of fencing should be used to prevent individuals from illegally dumping or using ATVs. A 36" opening may be provided if there is a greenway walking trail access point. Access control fencing should be used along roads, at the ends of roads, and along parking lots to control vehicle access (including ATVs and motorized vehicles), and dumping.</p> <p>Who is responsible for this? Stewards are responsible for purchasing, building, and installing access control fencing. All fencing must follow DCP standards.</p>
	<p>ENCROACHMENT FENCE</p> <p>Encroachment fences are designed to prevent property owners from expanding their lawn or other property into the greenways, but should not discourage visitors from entering the greenway from their homes. This type of fence should be installed between the greenway and private property and parks.</p> <p>Who is responsible for this? Stewards are responsible for purchasing, building, and installing encroachment fencing. All fencing must follow DCP standards.</p>
	<p>SWING GATE</p> <p>Swing gates should be used at major entry points where a utility, City department, or Authority requires vehicular access through or to the greenway. Swing gates should be flanked by access control fencing and should stand adjacent to a 36" gap that allows for pedestrian access.</p> <p>Who is responsible for this? The City is responsible for purchasing, building, and installing swing gates.</p>
	<p>COLLAPSIBLE BOLLARD</p> <p>Collapsible bollards should be used at major entry points where a utility, City department, or Authority requires vehicular access through or to the greenway. Swing gates should be flanked by access control fencing where the total entry width is 8 feet to 11 feet. Collapsible bollards are desirable when there is not enough room for both a gate and a 36" gap in the fence to allow pedestrians through.</p> <p>Who is responsible for this? The City is responsible for purchasing, building, and installing collapsible bollards.</p>





PLANTINGS

Stewards are encouraged to include additional plantings in the greenway to highlight entries, create boundaries, contribute to their greenway's identity, and restore ecologically sensitive areas. Additional plantings in the greenway should be native to Western Pennsylvania. For more information about plant selection, planting strategies, and protecting your greenway from invasive species, please see the Greenways website. [www](#)

Who is responsible for this?

Stewards are responsible for choosing, purchasing, and planting additional vegetation.



TRAILS

Trails should connect greenway entry points to neighborhood amenities, other communities, other trails, or other points of interest. It is suggested that trails should be constructed where there is an existing walking path or along routes that do not require extensive removal of existing vegetation and wildlife habitat. The ecological integrity of proposed trail corridors should be considered when locating trails. Trail entries should be marked with signage indicating their name and level of difficulty.

Trails should be created with an expert trail partner (such as GPs) and should be reviewed with the Greenways Program Manager. Before construction, trails need to be walked with a GPS to record the alignment and need to be approved by the Naming Commission.

Who is responsible for this?

Stewards, with a qualified trail building partner, are responsible for identifying and constructing trails. All trails should be built to the trail-building guidelines found in *Pennsylvania Trail Design and Development Principles*, published by the Pennsylvania Department of Conservation and Natural Resources (DCNR). Stewards need to coordinate with the Greenways Program Manager and are encouraged to work with Greenway Partners (see the Greenways website for potential partners). [www](#)



GREEN INFRASTRUCTURE

Greenways may contain areas that manage stormwater with natural formations such as wetlands or constructed bioswales. This green stormwater infrastructure mimics the natural water cycle to encourage stormwater infiltration and/or detention. Often this infrastructure will be part of a utility easement, especially if it is part of a municipal stormwater control system. In some cases, greenway stewards may want to create small biohabitats that assist in stormwater control. Check with the Greenways Program Manager for the appropriate size and location for green infrastructure in your greenway.

Who is responsible for this?

Stewards may identify projects and may be able to do some construction. Stewards are encouraged to work with the City, PWSA, and other partner organizations and non-profits on how to best implement green infrastructure (see the Greenways website for potential partners). [www](#)



ART INSTALLATIONS

Environmental art or eco-art is an artistic expression that focuses on ecological themes. This may include conservation of flora and fauna, or it may integrate elements of the natural environment (such as stones, branches, or sand), all without contributing to ecological degradation. This type of art advocates for a harmonious co-existence between human beings and nature.

Who is responsible for this?

Stewards may identify projects and sites and will work with the Public Art and Civic Design Division at the City to understand how to best implement the project and how to best present proposals to the Art Commission.

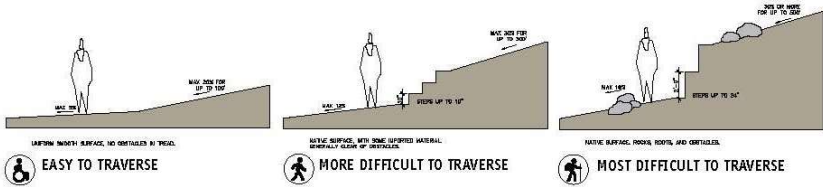

HINGED BOLLARD

MATERIALS NEEDED:

1/4" x 8" x 6" x 19" STEEL TUBE (1)
 7-5/8" x 4-5/8" x 3/16" STEEL PLATE (1)
 8-1/4" x 6" x 5/8" STEEL PLATE (1)
 6-1/2" x 13-3/8" x 5/8" STEEL PLATE (2)
 2" x 1/2" x 3/16" ANGLE (2)
 1" DIAM. x 9-1/2" STEEL PIN (2)
 1/8" x 2" PIN (2)
 1/2" PLATE, 2" DIAM. (1)
 CONCRETE

NOTES:

1. This unit shall be entirely galvanized.
 2. This unit will be built and installed by DPW.

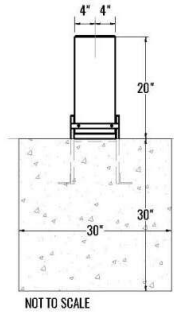

SIDE ELEVATION

SECTION A-A

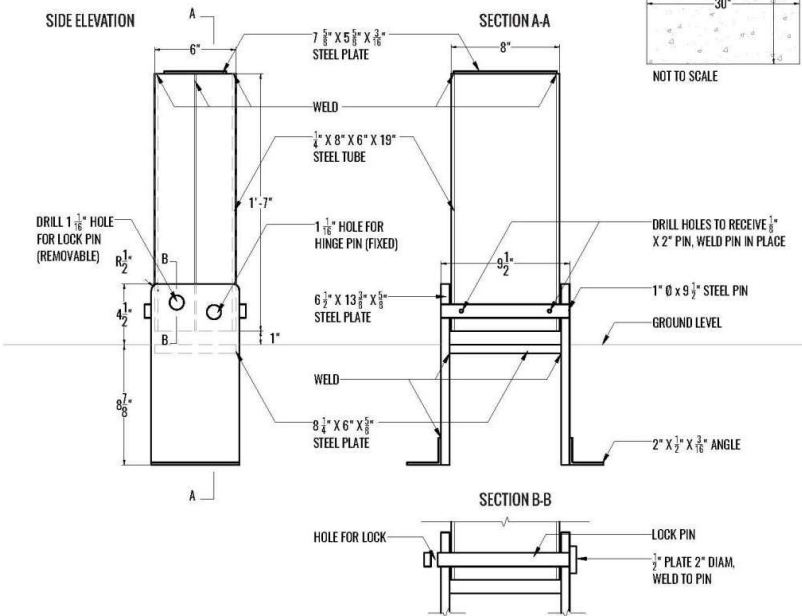

GREENWAYS BENCH

MATERIALS NEEDED:

2" x 6" x 10' LUMBER (2)
 2" x 6" x 8' LUMBER (2)
 1/4" x 2-1/2" LAG SCREWS (14)
 1/4" WASHERS (14)
 3" OUTDOOR SCREWS (40)

TOOLS NEEDED:

CIRCULAR SAW
 DRILL
 IMPACT DRIVER
 BITS FOR SCREWS (2 TYPES)
 SPEED SQUARE
 MEASURING TAPE
 CLAMPS
 MITRE SAW (OPT)

NOTE:

Bench can be made 2' wide as shown or 4' wide. A 4'-wide bench requires seven (7) 2" x 6" x 8' boards and zero (0) 2" x 6" x 10' boards. Other materials are the same as for a 2'-wide bench. Change slat length to 4'. Other dimensions are the same.

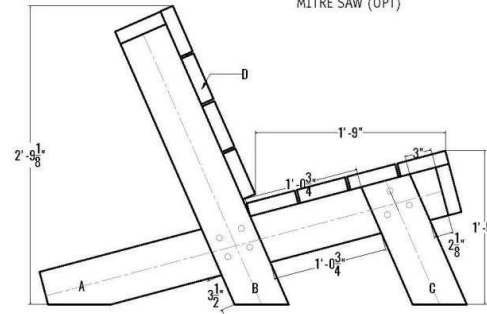

SIDE ELEVATION

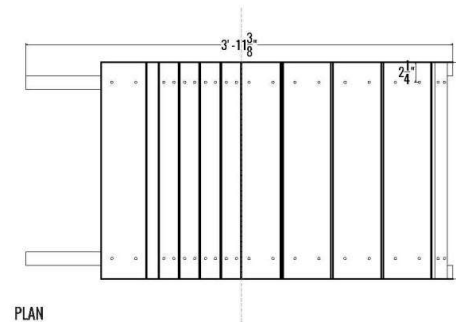

PLAN

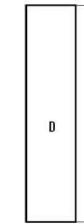

SLAT X 10

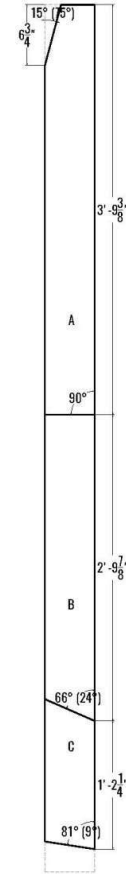

LEG X 2



GREENWAYS 2.0
 DESIGN STANDARD

PROJECT NAME:

LOCATION:

DRAWING: HINGED BOLLARD

SCALE: 1/2" = 1'-0"



GREENWAYS 2.0
 DESIGN STANDARD

PROJECT NAME:

LOCATION:

DRAWING: GREENWAYS BENCH

SCALE: 1" = 1'-0"



ACCESS CONTROL FENCE

MATERIALS NEEDED:
 2" x 10" x 8' LUMBER (VAR.; 2 PER 8' SEGMENT)
 4" x 4" x 10' POSTS (VAR.; 1 YIELDS 2 POSTS)
 NAILS (12 PER 8' SEGMENT)

TOOLS NEEDED:
 SAW
 HAMMER
 STAKES AND STRING
 MEASURING TAPE
 LEVEL
 POST HOLE DIGGER OR AUGER
 SHOVEL

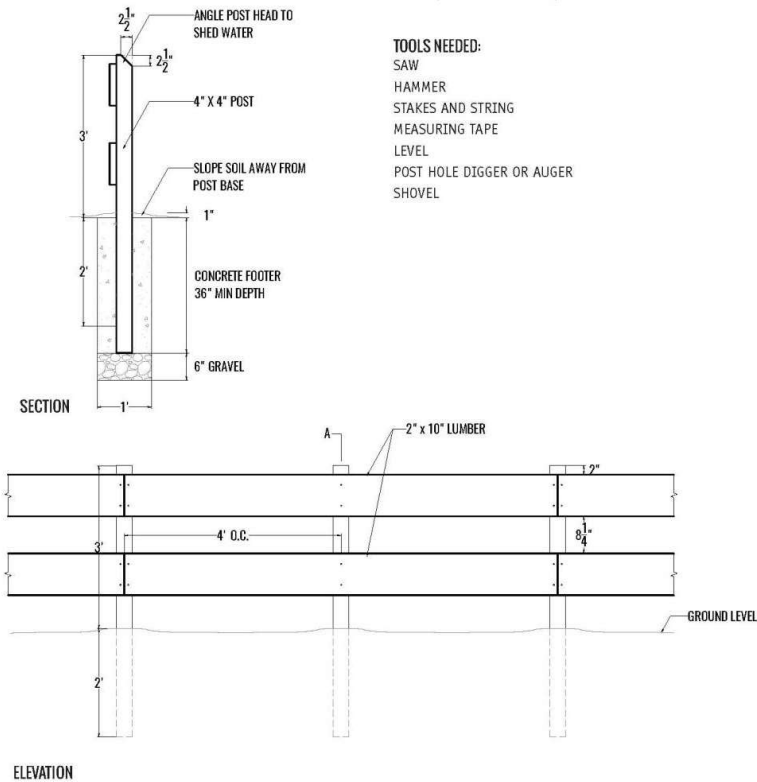

ELEVATION

GREENWAYS BENCH TOP

MATERIALS NEEDED:
 2" x 6" x 8' LUMBER (3)
 3" OUTDOOR SCREWS (52)
 LOGS, MAX DIAM. 16" (2)

TOOLS NEEDED:
 CIRCULAR SAW OR MITRE SAW
 DRILL
 IMPACT DRIVER
 BIT FOR SCREWS (USU. INCLUDED W/ SCREWS)
 CLAMPS (OPT)

PLAN

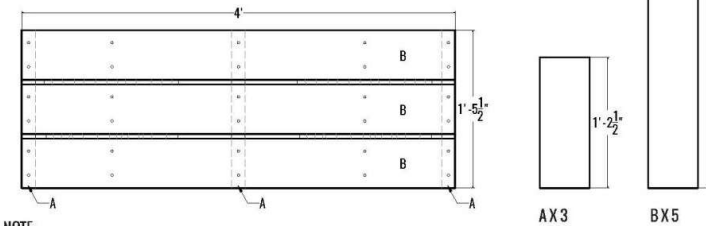

NOTE:
 Logs are from trees
 felled or trails cleared by
 DPW Forestry Division.
 Greenways stewards
 should not use chainsaws
 in the greenways.

FRONT ELEVATION

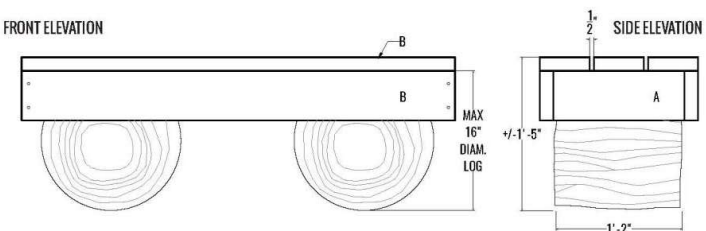

SPLIT-RAIL BOUNDARY FENCE

MATERIALS NEEDED:

8' PRECUT RAILS (VAR.)
4" x 4" x 5-1/3 FT LINE POSTS (VAR.)
4" x 4" x 5-1/3 FT END POSTS (2)
GRAVEL

TOOLS NEEDED:

STAKES AND STRING
MEASURING TAPE
LEVEL
POST HOLE DIGGER OR AUGER
SHOVEL

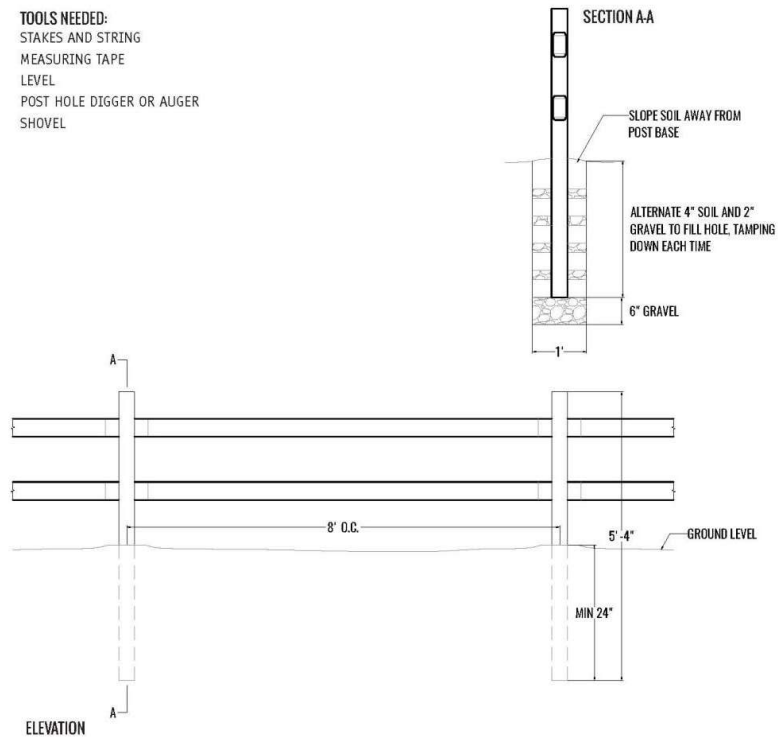

GREENWAYS 2.0
DESIGN STANDARD

PROJECT NAME:

LOCATION:

DRAWING: SPLIT-RAIL FENCE

SCALE: 1/2"=1'-0"

